

**4-HEAD PLAYBACK AND RECORD AMPLIFIER FOR VCR**

ADVANCE DATA

- ONE 5V POWER SUPPLY
- PLAYBACK/RECORD MODE SELECTION THROUGH A LOGIC INPUT
- SO20 PACKAGE
- NO ADJUSTMENT FOR LUMINANCE RECORDING

**PLAYBACK MODE**

- LOW NOISE AND WIDE BAND AMPLIFIERS FOR 4 HEADS
- AUTOMATIC OFFSET CANCELLATION BETWEEN THE 2 SELECTED HEADS
- ONE PLAYBACK OUTPUT
- ONE OUTPUT FOR AUTOMATIC VIDEO TRACKING
- SP/LP ENVELOPE COMPARATOR
- SHORT-CIRCUIT SWITCHES ON UNUSED HEADS

**RECORD MODE**

- RECORD AGC AMPLIFIER SAMPLED BY SYNCHRO SIGNAL
- RECORDING SIGNAL LEVEL ADJUSTABLE BY EXTERNAL RESISTOR
- SHORT-CIRCUIT SWITCHES ON UNUSED HEADS

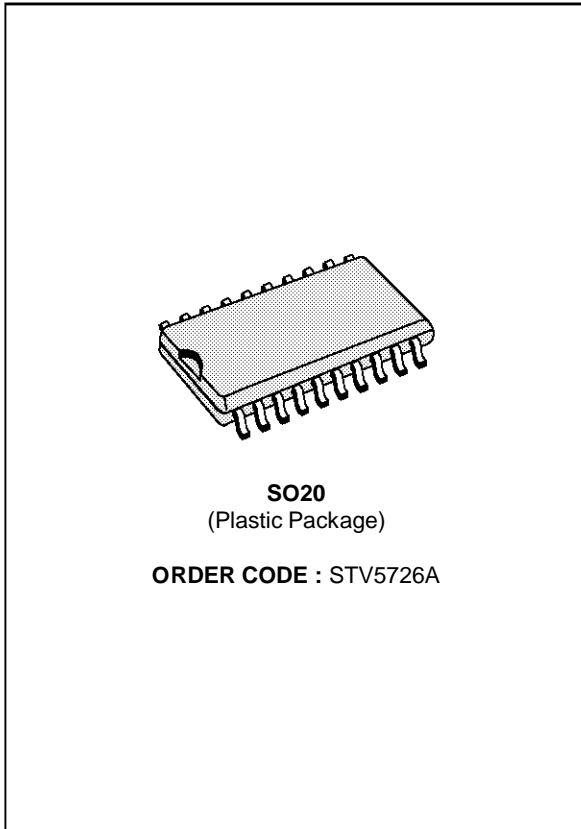

**PIN CONNECTIONS**

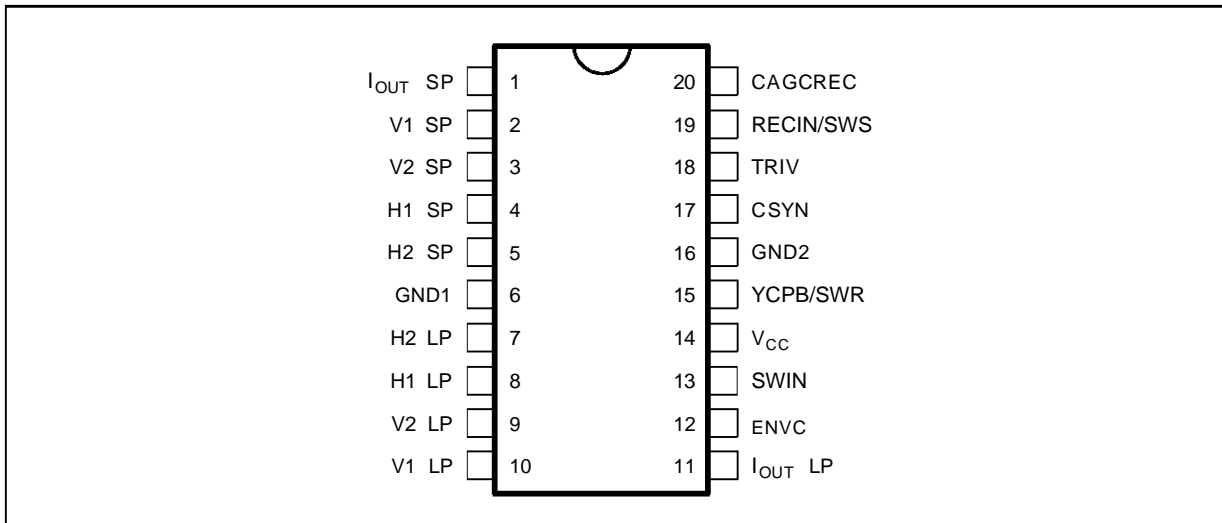

5726A-01.EPS

# STV5726A

## BLOCK DIAGRAM

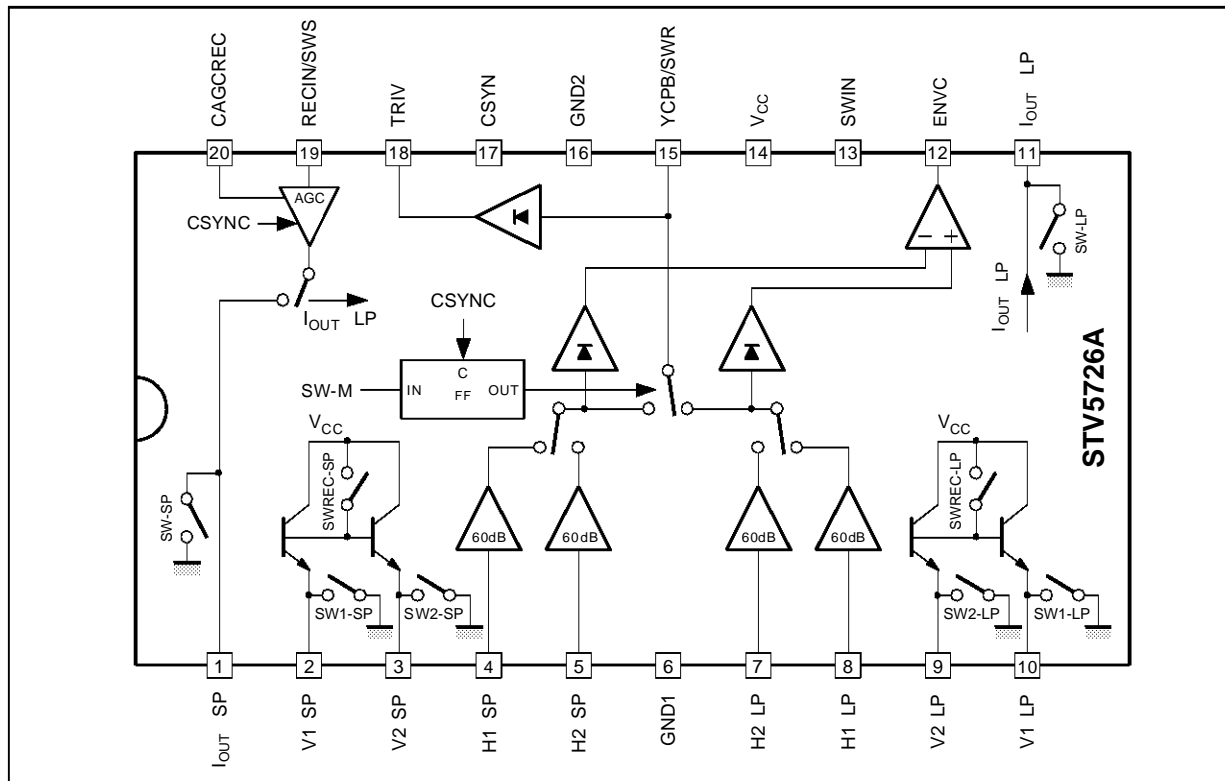

5726A-02.EPS

## ABSOLUTE MAXIMUM RATINGS

Symbol	Parameter	Value	Unit
$V_{CC}$	Power Supply Voltage	6	V
$T_j$	Junction Temperature	150	$^{\circ}\text{C}$
$T_{oper}$	Operating Temperature	0, +70	$^{\circ}\text{C}$

5726A-01.TBL

## THERMAL DATA

Symbol	Parameter	Value	Unit
$R_{th(j-a)}$	Junction-ambient Thermal Resistance	Max. 75	$^{\circ}\text{C/W}$

5726A-02.TBL

## RECOMMENDED OPERATING CHARACTERISTICS

Symbol	Parameter	Min.	Typ.	Max.	Unit
$V_{CC}$	Power Supply	4.75	5	5.25	V
CAGC	Capacitance on Pin CAGCREC	4.7			nF
RECADJ	Record Biasing Resistor	10		33	k $\Omega$

5726A-03.TBL

**ELECTRICAL CHARACTERISTICS** ( $T_{amb} = 25^{\circ}\text{C}$ , unless otherwise specified)**Playback Mode** ( $V_{CC} = 5\text{V}$ , no load on Pin YCPB, Recadj =  $12\text{k}\Omega$ )

Symbol	Parameter	Test Conditions	Min.	Typ.	Max.	Unit
--------	-----------	-----------------	------	------	------	------

## PLAYBACK AMPLIFIER

$I_{CC1}$	Supply Current		42	52	62	mA
GPB	Playback Gain	Sinewave 600kHz, $0.4\text{mV}_{PP}$ on inputs	55	57	59	dB
EN	Equivalent Voltage Noise	Input grounded via $I_{OUT}$ Pin @ 600kHz, BW = 10kHz		0.6		$\frac{\text{nV}}{\sqrt{\text{Hz}}}$
IN	Equivalent Input Current	Input open @ 6MHz, BW = 10kHz		2		$\frac{\text{pA}}{\sqrt{\text{Hz}}}$
CRT1	Crosstalk (LP → SP)	Sinewave @ 4MHz, $0.4\text{mV}_{PP}$		-45	-40	dB
CRT2	Crosstalk (SP → LP)	Sinewave @ 4MHz, $0.4\text{mV}_{PP}$		-41	-35	dB
RPBSW	Playback Switch on Resistor	@ 6MHz	5	10	15	$\Omega$
BWLCF	Attenuation @ 100kHz	Reference level @ 600kHz	-3	-2	1	dB
BWHCF	Attenuation @ 8MHz	Reference level @ 4MHz	-3	-1	0	dB
$C_{IN}$	Input Capacitance	@ 6MHz, 22nF between Vi/Hi	40	50	60	pF
$Z_{IN}$	Input Impedance	@ 6MHz	300	450	600	$\Omega$
ZCPB	Output Resistance	DC	5	24	50	$\Omega$
VDCPB1	DC Level on Pin YCPB		1.6	2	2.4	V
DVDC	Head Switch Offset		-0.2	0	0.2	V
SHPB1	2nd Harmonic	Sinewave @ 4MHz, $0.4\text{mV}_{PP}$		-45	-40	dB
RCST	Off-resistance on unused channel	SW-S high	10	15	20	$\Omega$

## TRIV FUNCTION

TRIV0	Output Level (1)	No input signal	0	0.1	1	V
TRIV1	Output Level (2)	Sinewave @ 4MHz, $100\text{mV}_{PP}$ @ YCPB		1.3		V
TRIV4	Output Level (3)	Sinewave @ 4MHz, $400\text{mV}_{PP}$ @ YCPB	2.5	3.1	3.5	V
TRIV6	Output Level (4)	Sinewave @ 4MHz, $600\text{mV}_{PP}$ @ YCPB	3.15	3.65	4.15	V

## SP/LP ENVELOPE DETECTOR

$R_{OH}$	Output Resistance @ ENVC	Sinewave $600\mu\text{V}_{PP}$ @ 4MHz on H1LP CSYN signal applied		22		$\text{k}\Omega$
$R_{OL}$	Output Resistance @ ENVC	Sinewave $600\mu\text{V}_{PP}$ @ 4MHz on H2SP CSYN signal applied		2		$\text{k}\Omega$
VENVCH	Output Level		4	4.8	5	V
VENVCL	Output Level		0	0.1	1	V
SENS1	Sensitivity	$100\mu\text{V}_{PP}$ to $600\mu\text{V}_{PP}$ @ SP input pins		0.1	1	V
SENS2	Sensitivity	$100\mu\text{V}_{PP}$ to $600\mu\text{V}_{PP}$ @ LP input pins	4	4.8		V

5726A-04.TBL

## STV5726A

**ELECTRICAL CHARACTERISTICS** ( $T_{amb} = 25^{\circ}\text{C}$ , unless otherwise specified (continued))

**Record Mode** ( $V_{CC} = 5\text{V}$ ,  $\text{Recadj} = 12\text{k}\Omega$ ,  $\text{SWR} = 5\text{V}$ ,  $\text{CAGCREC} = 470\text{pF}$ ,  $\text{RRCY} = 2.2\text{k}\Omega$ ,  $\text{RRCC} = 8.2\text{k}\Omega$ , Load  $10\mu\text{H}/1\text{k}\Omega$  for each simulated head)

Symbol	Parameter	Test Conditions	Min.	Typ.	Max.	Unit
--------	-----------	-----------------	------	------	------	------

### RECORD AMPLIFIER

I <sub>CC2</sub>	Current Supply		70	85	100	mA
I <sub>HA0</sub>	DC Current through I <sub>OUT</sub>		21	27	34	mA
I <sub>HA1</sub>	Fundamental	V <sub>R</sub> = 300mV <sub>PP</sub> @ 4MHz	20	23	26	mA <sub>PP</sub>
I <sub>HA2</sub>	2nd Harmonic	V <sub>R</sub> = 300mV <sub>PP</sub> @ 4MHz		-45	-38	dB
BWRECL	Attenuation at 100kHz	Reference level @ 600kHz, AGC locked	-3	0	1	dB
BWRECH	Attenuation at 8MHz	Reference level @ 4MHz, AGC locked	-2	-0.5	1	dB
DVLR	Record AGC Sensitivity	V <sub>IN</sub> = 300mV <sub>PP</sub> ±3dB @ f = 4MHz	-1	0	+1	dB
R <sub>IOUT</sub>	Output Resistance	ΔV = 5V		800		Ω
R <sub>SAT</sub>	Output Stage Resistance	ΔI = 10mA				Ω
I <sub>RN</sub>	AGC Capacitor downloading Current	4.5V at CAGC Pin		160		μA
I <sub>RP</sub>	AGC Capacitor uploading Current	0.5V at CAGC Pin, V <sub>IN</sub> = 300mV <sub>PP</sub> @ 4MHz		-165		μA

### SWITCHING LEVELS

V <sub>SWINH</sub>	SWIN Input Voltage	Selects head H2LP	4.75		5	V
V <sub>SWINL</sub>	SWIN Input Voltage	Selects head H2SP	0		0.25	V
V <sub>SWIN2</sub>	SWIN Input Voltage	Selects head H1LP	2.75		4.25	V
V <sub>SWIN1</sub>	SWIN Input Voltage	Selects head H1SP	0.75		2.25	V
I <sub>SWINH</sub>	SWIN Input Leakage Current	5V at SWIN input		0.5		μA
I <sub>SWINL</sub>	SWIN Input Leakage Current	0V at SWIN input		-0.2		μA
V <sub>SWRCH</sub>	SWRC Input Threshold	Selects record mode, 0 to 5V	3.2	3.4	3.8	V
V <sub>SWRCL</sub>	SWRC Input Threshold	Selects playback mode, 5 to 0V	3.1	3.35	3.8	V
I <sub>SWRCH</sub>	SWRC Input Leakage Current	5V at SWRC input	2	5	8	mA
I <sub>SWRCL</sub>	SWRC Input Leakage Current	0V at SWRC input	-20	0	20	μA
t <sub>ON</sub>	Delay	Signal appears on YCPB		1.6		ms
t <sub>1</sub>	Delay from playback to record : Signal disappears on Pin YCPB	22nF between Hi/Vi		1		μs
t <sub>2</sub>	Delay from record to playback : Signal appears on Pin YCPB			1.9		ms
t <sub>3</sub>	Delay from playback to record : Signal appears on Pin I <sub>OUT</sub>	V <sub>R</sub> = 300mV <sub>PP</sub> @ 4MHz		2		ms
t <sub>4</sub>	Delay from record to playback : Signal disappears on Pin I <sub>OUT</sub>			10		μs
V <sub>CSYH</sub>	CSYN Input Threshold	Sampling on, 0 to 5V	2.0	2.7	3.2	V
V <sub>CSYL</sub>	CSYN Input Threshold	Sampling off, 5 to 0V	2.0	2.6	3.1	V
I <sub>CSYH</sub>	Leakage Current	5V at CSYN Pin, Sampling on	-10	0	10	μA
I <sub>CSYL</sub>	Leakage Current	0V at CSYN Pin, Sampling off	-50	-16	-5	μA
V <sub>SWST</sub>	SWS Input Threshold			3		V
I <sub>SWSH</sub>	SWS Input Leakage Current	5V at SWS Input		130		μA
I <sub>SWSL</sub>	SWS Input Leakage Current	0V at SWS Input	-20	0	20	μA

5726A-05.TBL

APPLICATION DIAGRAM

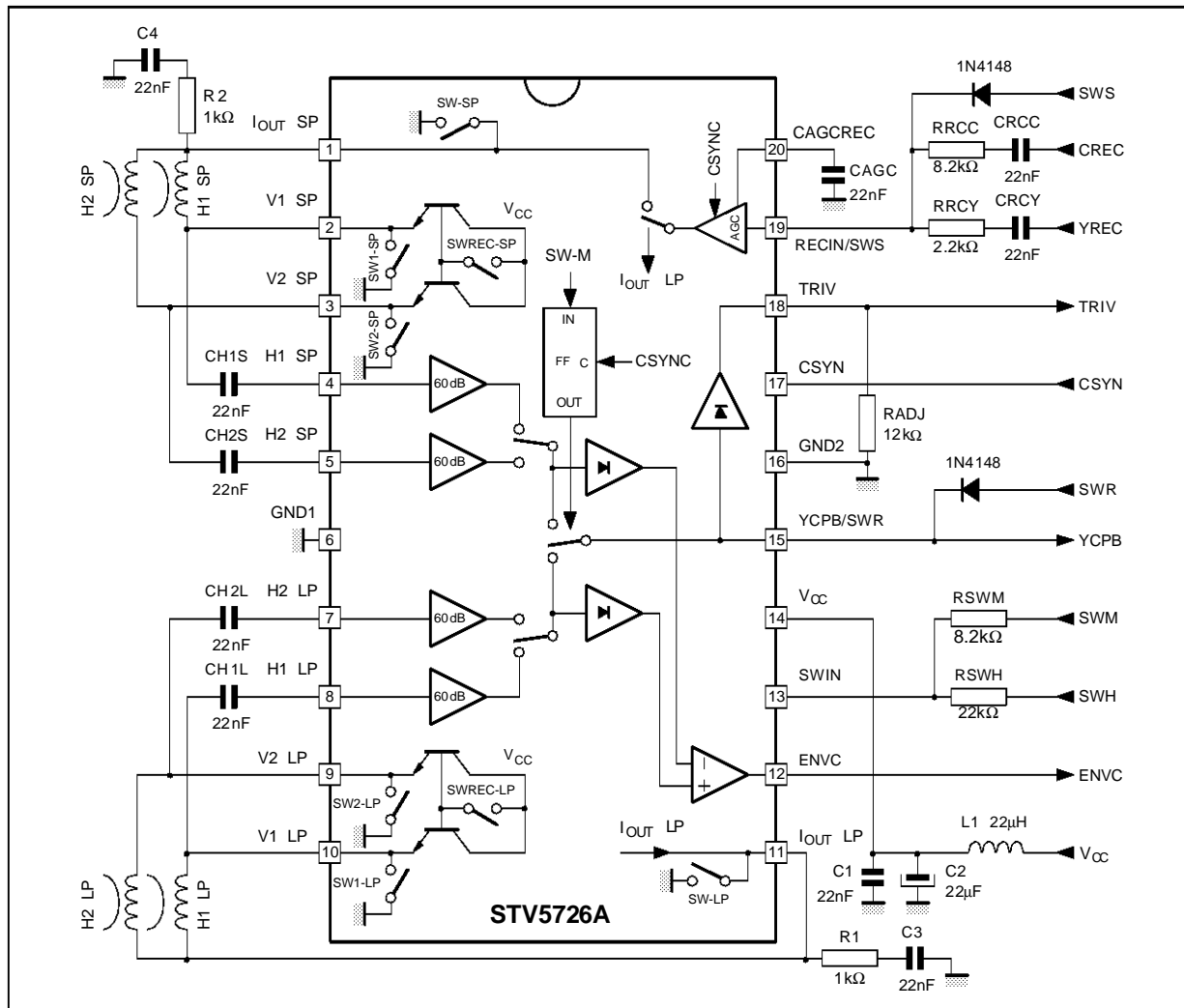

5726A-03.EPS

SWITCH TABLE

SW-R	SW-M	SW-S	SW-H	Channel	SW1-SP SW2-SP	SW1-LP SW2-LP	SW-SP	SW-LP	SWREC-SP	SWREC-LP	ENVC (SPLP)	
L	L	L	L	2-SP	OFF	OFF	ON	ON	OFF	OFF	High IF LP > SP Low IF LP < SP	
			H	1-SP								
	L		1-LP									
	H		2-LP									
	L	H	H	L	2-SP	OFF	ON	ON	OFF	OFF		
				H	1-SP							
L	1-LP											
H	2-LP											
H	L	L	L	SP	OFF	ON	OFF	ON	ON	OFF	0V (1)	
			H	LP							High Impedance (1)	
	H		H	H	L	LP	ON	OFF	ON	OFF	ON	High Impedance (1)
					H	LP						0V (1)

5726A-06.TBL

**Note :** 1. The recording current can be set different for each of the four heads. To perform it the ENVC output is either at low level or high impedance according to the selected head or mode. Then two external resistors with adequate value have to be connected respectively between the ENVC and TRIV and SWM and TRIV, playing so that on the equivalent value of the RADJ resistor.

# STV5726A

## PACKAGE MECHANICAL DATA

20 PINS - PLASTIC MICROPACKAGE (SO)

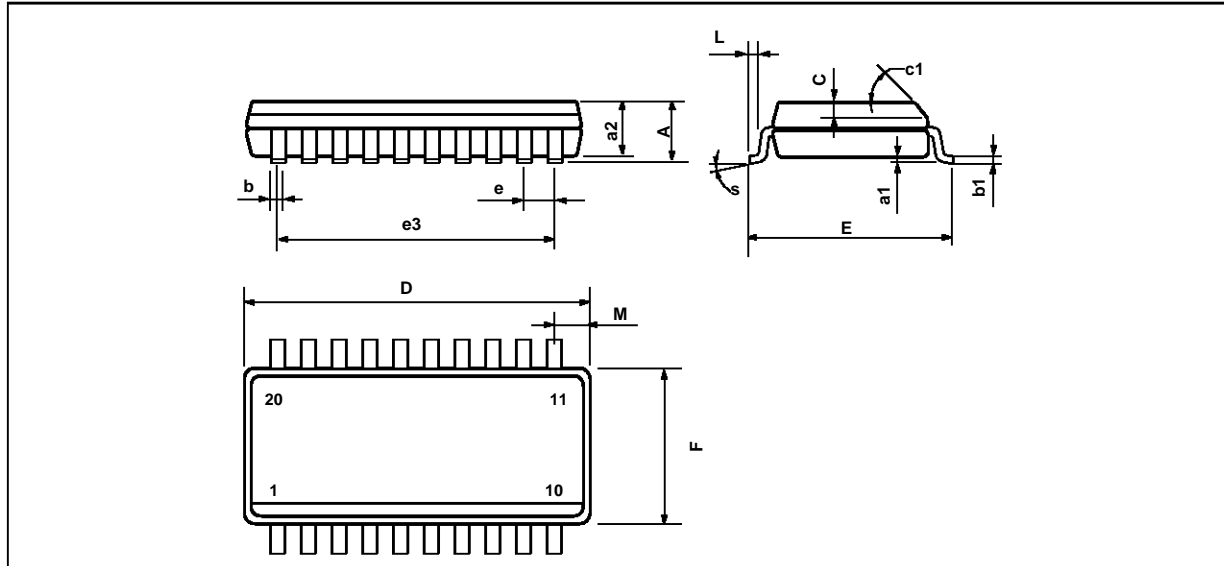

PM-SO20L.EPS

Dimensions	Millimeters			Inches		
	Min.	Typ.	Max.	Min.	Typ.	Max.
A			2.65			0.104
a1	0.1		0.2	0.004		0.008
a2			2.45			0.096
b	0.35		0.49	0.014		0.019
b1	0.23		0.32	0.009		0.013
C		0.5			0.020	
c1	45° (typ.)					
D	12.6		13.0	0.496		0.510
E	10		10.65	0.394		0.419
e		1.27			0.050	
e3		11.43			0.450	
F	7.4		7.6	0.291		0.300
L	0.5		1.27	0.020		0.050
M			0.75			0.030
S	8° (max.)					

SO20L.TBL

Information furnished is believed to be accurate and reliable. However, SGS-THOMSON Microelectronics assumes no responsibility for the consequences of use of such information nor for any infringement of patents or other rights of third parties which may result from its use. No licence is granted by implication or otherwise under any patent or patent rights of SGS-THOMSON Microelectronics. Specifications mentioned in this publication are subject to change without notice. This publication supersedes and replaces all information previously supplied. SGS-THOMSON Microelectronics products are not authorized for use as critical components in life support devices or systems without express written approval of SGS-THOMSON Microelectronics.

© 1994 SGS-THOMSON Microelectronics - All Rights Reserved

Purchase of I<sup>2</sup>C Components of SGS-THOMSON Microelectronics, conveys a license under the Philips I<sup>2</sup>C Patent. Rights to use these components in a I<sup>2</sup>C system, is granted provided that the system conforms to the I<sup>2</sup>C Standard Specifications as defined by Philips.

SGS-THOMSON Microelectronics GROUP OF COMPANIES

Australia - Brazil - China - France - Germany - Hong Kong - Italy - Japan - Korea - Malaysia - Malta - Morocco  
The Netherlands - Singapore - Spain - Sweden - Switzerland - Taiwan - Thailand - United Kingdom - U.S.A.